

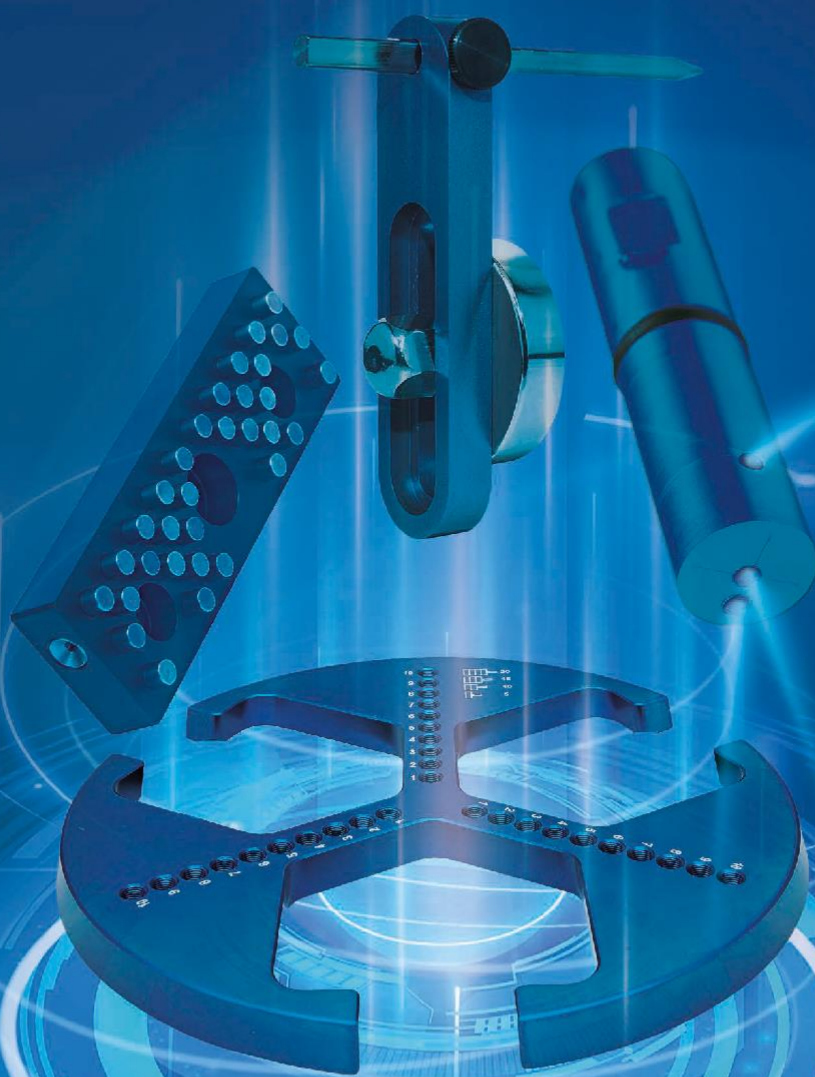

UHLE



2024 NEWS

Alle Preise in EUR + zzgl. MwSt. - gültig bis zum 31.12.2024



**ADATTO PER MORSE:
 PASSEND FÜR SCHRAUBSTÖCKE:
 SUITABLE FOR VICES:**

- ALLMATIC NC8 125/160, HD 125/160, TC, TITAN2 125/160
- ARNO 125/160
- BULL pneumatik 125/160, mechanisch 125/160
- GRESSEL Gripos GPS125/160, Gripos GPS125/160-VS, Gripos 2, Grepos-5S/5X-S, Grefors, S2 Duogrip, C2, Ecopos
- HILMA NC125/160, NC125/160H, EL125/160, KNC125/160
- KESEL CNC125/160
- RÖHM RKE125/160, RKE-L125/160, RKE-U125/160, RKG-L125/160, RKE-LV125/160
- WNT NCG 125/160, DSG4 125, HDG2 125/160, 1-15G 125, ZSG4 125/160, ESG4 125/160

- ✓ SISTEMA BREVETTATO DI GANASCE DI SERRAGGIO
PATENTIERTES SPANNBACKEN-SYSTEM
 PATENTED CLAMPING JAW SYSTEM
- ✓ FISSAGGIO RAPIDO
SCHNELLE LAGEFIXIERUNG
 FAST POSITION FIXING
- ✓ RIUTILIZZABILE
WIEDERVERWENDBAR
 REUSABLE
- ✓ VERSATILE
VIELSEITIG
 VERSATILE

DESIGN

- Robusto e stabile, per elevate forze di serraggio e una lunga durata di servizio.
- In acciaio per utensili, temprato e rettificato.
- I perni ad alta precisione fungono sia da supporto che da bloccaggio del pezzo da lavorare.
- Bassa manutenzione (manutenzione regolare con olio).
- Funzionamento semplice tramite pistola ad aria compressa standard - Valvole su entrambe le estremità per la massima facilità d'uso.

AUSFÜHRUNG

- *Robust und stabil, für hohe Spannkraft und eine lange Lebensdauer.*
- *Ausführung aus Werkzeugstahl; gehärtet und geschliffen.*
- *Die hochgenauen Stifte dienen als Auflage wie auch als Werkstückanschlag.*
- *Wartungsarm (regelmäßig mit Öl leichtgängig halten).*
- *Einfachste Bedienung über Standard-Druckluftpistole - Ventile an beiden Stirnseiten für höchste Bedienerfreundlichkeit.*

DESIGN

- Robust and stable, for high clamping forces and a long lifetime.
- Made of tool steel; hardened and grinded.
- The high-precision pins perform as a support as well as a workpiece stop.
- Low maintenance (regularly keep it running smoothly with oil).
- Easy handling using standard compressed air gun - Valves on both ends for maximum user-friendliness.



VANTAGGI _ VORTEILE _ BENEFITS

- Fissaggio della posizione rapido e assolutamente ripetibile, comodo e variabile.
- Riduce al minimo lo sforzo necessario per il bloccaggio dei pezzi di forme diverse e per il fissaggio della posizione.
- Adattamento preciso senza programmazione e lavorazione.
- I listelli di supporto possono essere omessi.
- La soluzione più rapida ed economica per i pezzi complessi.
- Dimensione del lotto 1: NESSUN PROBLEMA!
- Riutilizzabile: risparmia tempo e denaro!
- Montaggio semplice grazie alla chiusura a vite della morsa.
- Adatto per ganasce fisse e mobili.
- Non deve mancare in nessuna produzione meccanica: che si tratti di produzione di prototipi, piccole serie o riparazioni.
- *Lagefixierung schnell und absolut wiederholgenau, komfortabel und variabel.*
- *Minimiert den Aufwand zum Spannen von unterschiedlichen Werkstückformen und zur Lagefixierung.*
- *Passgenau ohne Programmierung und Zerspanung.*
- *Auflageleisten können entfallen.*
- *Schnellste und kostengünstigste Lösung für komplexe Bauteile.*
- *Losgröße 1: KEIN PROBLEM!*
- *Wiederverwendbar: SPART ZEIT UND GELD!*
- *Einfachste Montage über Schraubensicherung auf dem Schraubstock.*
- *Sowohl für Fest- als auch Mobilbacke geeignet.*
- *Sollte in keiner mechanischen Fertigung fehlen: egal ob Prototypenfertigung, Kleinserie oder Reparatur.*
- Position fixing fast and absolutely repeatable, comfortable and variable.
- Minimises the effort required for clamping different workpiece shapes and for position fixing.
- Accurate fit without programming and machining.
- Jaw inserts can be omitted.
- Fastest and cheapest solution for complex work pieces.
- Batch size 1: NO PROBLEM!
- Reusable: saves time and money!
- Simple assembly with screw lock on the vice.
- Suitable for both fixed and mobile jaws.
- No mechanical production should be without it: no matter if prototype production, small series or repair.





 **PROFI-BOX**



STOCK



Art. SET 103.125.0050	n° 2		103.125.0050	256,-	● 509,-
Art. SET 103.160.0050	n° 2		103.160.0050	319,-	● 638,-

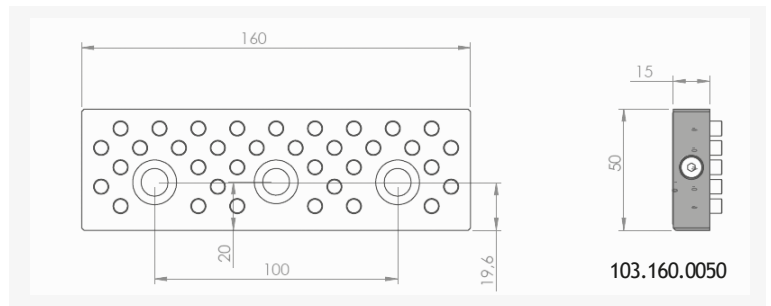
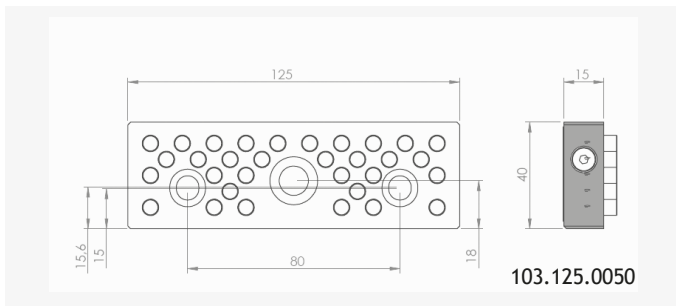

FLEX-STOP

FERMAPEZZO PER MORSE
 WERKSTÜCKANSCHLAG FÜR SCHRAUBSTOCK _ WORKPIECE BACK-STOP FOR VICES

DESIGN con magnete al neodimio (forza di tenuta: 52 kg) in confezione a sistema WAG. Ganaschia in acciaio inox e alluminio anodizzato blu per una marcatura e un posizionamento ottimale del marchio sulla morsa. Posizionamento del pezzo nella morsa in pochissimo tempo, flessibile, universale e senza uso di attrezzi.

AUSFÜHRUNG mit Neodym-Topfmagnet (Haltekräft: 52 kg) in WAG Systemverpackung. Rostfreier Stahl und Aluminiumbacke blau eloxiert für optimale Signierung und Markenpositionierung am Schraubstock. Werkzeuglose, flexible und universelle Werkstückpositionierung im Schraubstock in kürzester Zeit.

DESIGN with Neodymium pot magnet (holding force: 52 kg) in WAG system packaging. Stainless steel and aluminium jaw anodised blue for optimum marking and brand positioning on the vice. Tool-free, flexible and universal placement of the workpiece in the vice in quickest time.



 **PROFI-BOX**
FSMUMB

STOCK





Art. FSMUMB	● 67,-
-------------	--------



SET FSMUTB

PROTECTED DESIGN

	n	h	€NET/PC.	STOCK	€NET/SET
Art. SET FSMUTB	n° 1 	25	15	-	● 149,-
	n° 12 	SET FSTB	48,-		

DESIGN

- Fermapezzo Magnetico, blu, regolabile universalmente (15 / 20 / 25 / 30 / 35 mm) per torni.
- 12 viti distanziatrici (3x5 mm, 3x10 mm, 3x15 mm, 3x20 mm) con filetto M5 e tacca per l'allineamento dell'altezza.
- Filetti M5 numerati 1-10 come ausilio di posizionamento degli elementi elevatori.
- Fresando le traverse è possibile raggiungere una larghezza delle pinze fino a 55 mm (vedi Dimensione n).

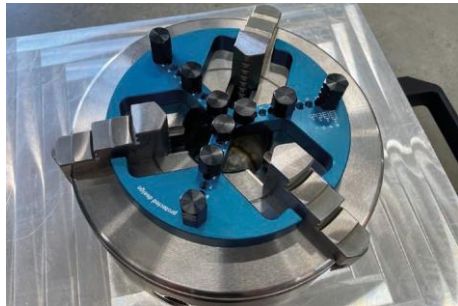

AUSFÜHRUNG

- *Magnetischer Werkstückanschlag, blau, universell einstellbar (15 / 20 / 25 / 30 / 35 mm) für Drehmaschinen.*
- *12 Stehbolzen (3x5 mm, 3x10 mm, 3x15 mm, 3x20 mm) mit M5 Gewinde und Höhenorientierungskerbe.*
- *M5 Gewinde mit Nummerierung 1-10 als Positionierungshilfe der Höheelemente.*
- *Durch Abfräsen der Stege bis Backenbreite 55 mm möglich (siehe Maße n).*

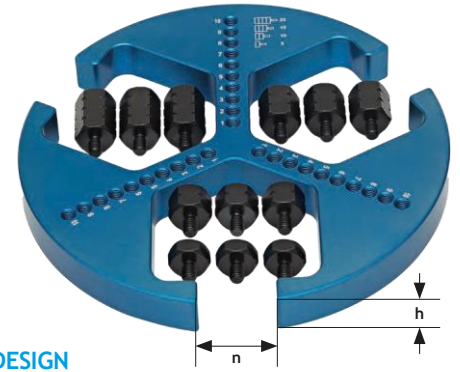
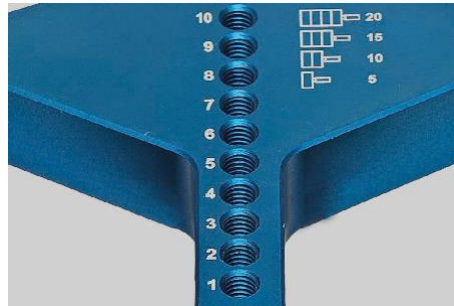

DESIGN

- Magnetic workpiece back-stop, blue, universally adjustable (15 / 20 / 25 / 30 / 35 mm) for turning machines.
- 12 stud bolts (3x5 mm, 3x10 mm, 3x15 mm, 3x20 mm) with M5 thread and height orientation notch.
- M5 threads numbered 1-10 as an aid for positioning the height elements.
- By milling off the ribs up to jaw width 55 mm can be achieved (see n dimension).

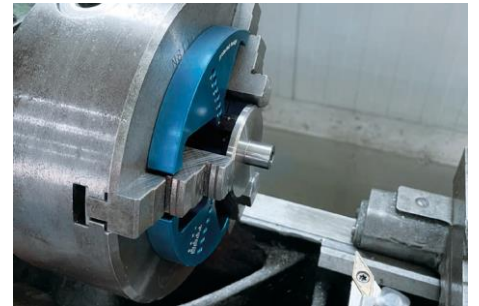

CLEAN-JET

UTENSILE PER PULIZIA
REINIGUNGSTOOL _ CLEANING TOOL

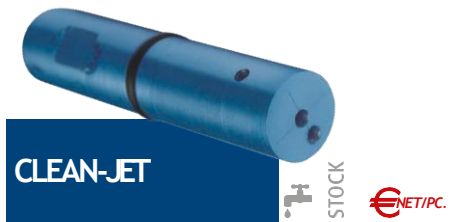

CLEAN-JET

Art. C-JET

STOCK
€NET/PC.
● 67,-

Attacco utensile <i>Werkzeugaufnahme</i> _ Tool holder	16 mm Weldon
Fori di pulizia <i>Reinigungsbohrung</i> _ Cleaning hole	2 axial + 1 radial
Velocità massima <i>Maximale Drehzahl</i> _ Maximum speed	60 RPM
Aria compressa <i>Druckluft</i> _ Compressed air	6 bar
Lubrificante di raffreddamento <i>Kühlschmiermittel</i> _ Cooling lubricant	max. 40 bar

Il **CleanJet** consente una pulizia efficace del pezzo, della morsa e della finestra di visualizzazione della macchina grazie ai fori di pulizia appositamente disposti e allineati. Il CleanJet è ideale anche per la pulizia di zone profonde.

- Pulizia automatizzata della morsa, del pezzo e della macchina
- Stabilità del processo grazie alla pulizia automatizzata
- Possibilità di pulizia con lubrificante refrigerante o aria compressa
- Semplice: si può utilizzare un supporto Weldon esistente per il diametro del gambo di 16 mm.

Der CleanJet ermöglicht durch die speziell angeordneten und ausgerichteten Reinigungsbohrungen eine effiziente Reinigung von Werkstück, Schraubstock und Maschinensichtfenster. Auch die Reinigung von tiefen Taschen ist der CleanJet ideal geeignet.

- *Reinigen Sie Ihren Schraubstock, Ihr Werkstück und Ihre Maschine automatisiert*
- *Prozessstabilität durch automatisierte Reinigung*
- *Reinigung mit Kühlschmiermittel oder Druckluft möglich*
- *Unkompliziert: nutzen Sie eine vorhandene Weldonaufnahme für Schaftdurchmesser 16 mm.*

The **CleanJet** enables efficient cleaning of the workpiece, vice and machine viewing window thanks to the specially positioned and aligned cleaning holes. The CleanJet is also ideal for cleaning deep pockets.

- Automated cleaning of your vice, your workpiece and your machine
- Process stability thanks to automated cleaning
- Cleaning with cooling lubricant or compressed air possible
- Easy: use an existing Weldon holder for shank diameter 16 mm.



● Disponibile - Lieferbar - On stock ○ A richiesta - Auf Anfrage - On request